

OPERATION MANUAL OF STRETCH-BLOW MOLDING MACHINE

1. Brief Introduction to the Blower	3
2. Main Technical Data	3
3. Main Features	
3.1 Master Blowing Unit	3
3.2 Reheating Unit	4
4. Explanation for Main Mechanism & Function of the Machine.	
4.1 Working-position arrangement & technical process	4
4.2 Machine's dimension and appearance	5
4.3 Master Bottle Blowing Unit	
1) Mold clamping unit	5
2) Stretch & Seal Unit.....	6
3) Mold-thickness Adjusting Unit	6
4) Air Storage Unit	6
5) Centralized type lubricate system	6
4.4 Per-form Reheating Units	7
4.5 Pneumatic system	8
4.6 Electric System and Control System	
1) Function introduction of master bottle blowing unit's panel	9
2) Function introduction of reheating unit's panel	9
3) Electrical connection	10
4) Adjustment and operation of PLC control system	10
5) Adjustment and operation of reheating unit	13
6) Electric wire connecting diagram	13
5. Installation, Adjustment & Operation of the machine	
5.1 Installation of master bottle blowing unit	14
5.2 Installation of the air-input pipes	14
5.3 Installation of Stretch-Seal Cylinder	16
5.4 Installation of the Reheating Unit	16
5.5 Installation & Adjustment of the Mold	16
5.6 Adjustment of Sealing mouth & Stretch	17
5.7 Operation of Bottle Production	17
6. Maintenance of the Machine	17
7. Problems and solution	18
8. Abnormal Phenomenon and treatment	19
9. Specifications of Seal Rings	19

1 Brief Introduction To the Blower

Stretch-blow Molding machine is newly designed and reformed on previous experiences of our manufacture (with great development on the aspect of 2-in-1 cylinder structure, new model mold-clocked set and automatic voltage-regulating set of temperature controller of reheating unit). The mechanical structure is reasonable and compact with small volume, lightweight and artistic shape. Controlled by reliable electrical and pneumatic systems, the machine runs steadily with low noise and very convenient to be operated. It is an ideal equipment to make different-shaped containers, such as mineral water bottles, beverage bottles, cosmetics bottles, medicine bottles, pesticide bottles, edible-oil bottles, wine bottles and milk bottles, which have passed the test given by the Packing Material Development and Inspection Center of China Medicine Authority. With less investment and high efficiency, it does help you raise production and save energy. Besides, it accords with demands of L Hygienic food.

L Hequips with an infrared type rotary-reheating unit to heat per-form. In the unit, we adopt far infrared heating lamps to heat the per-form from both sides. The per-form will be placed on the circulating discs of the heater. Along with the disc's rotation and revolution, the per-form will slowly spin into the heater and pass through heater's heating area to achieve uniform heating effect throughout its body and two walls. Moreover, we have also designed special cooling channels on the heater. With both effects of natural cooling and fan cooling, the heat won't accumulate on the circulating discs to affect per-forms correct heating effect. In addition, the circulating discs have several array modes for choice to fit per-forms with difference neck size, and can move very smoothly because of the nice cooperation of the per-form heating stand-frame's oriented mechanism. In conclusion, the reheating unit can heat several of per-form to produce diversified container.

2 Main Technical Data

Force of Closing Mold	800bottle/Hr (With 2-cavity mold)
Max. Voltmeter of Product	2L
Working Air Pressure of Main Engine	0.8-1.0Mpa
Plastic-Blowing Air Pressure	0.8-3.0Mpa
Heating Power	5~8KW
Max. Stretch Length	350mm
Max. Movable Mold Board Traveling Distance	230mm
Allowing Mold Thickness	180-280mm
Distance between Two Mold Centers	150-210mm
Power Supply	Three Phase AC380V Frequency HZ 50 60
General Motor Power	750W
Cooling Fan Motor Power in Motor Box	20W
Cooling Channels Fan Motor Power	40W
Top Exhaust Fan Motor Power	700W
Infrared Heating Lamp	28pcs
Power for Each Infrared Heating Lamp	600W
Linear Speed of Heating Stand-frame	10 mm/s
Width of Heating Channels	100~130 mm
Height of Heating Channels	300~330 mm
Range of Plastic Per-forms Neck Size	15~120 mm
Range of Plastic Per-forms Thickness	1~6 mm
Dimension of Master Blowing Unit	1.65x0.72x1.86mm
Dimension of Reheating Unit	1.89x0.71x1.57 mm
Weight of Master Blowing Unit	550Kg
Weight of Reheating Unit	280Kg

3 Main Features

3.1 Master Blowing Unit

- 1) **PLC Control System.** The full-digital displaying PLC control system control machine's operation including sealing, stretching, blowing and mold's moving, and all settings are interfaced through a user-friendly "soft-touch" pad, all data of operation are all shown on its LCD. Such PLC system's inner elements are all of only the high quality available, which ensure it to achieve time-control precision to 0.01 second. In addition, such PLC has also data memory function. It can store 12 sets of bottle blowing parameters of different blow mold. It is very easy to be operated, and be maintained conveniently.
- 2) **Advanced Per-form Heater.** The new designed multifunctional far-infrared plastic

per-form heater adopts automatic rotary heating mode. Under this heating mode, you can make the per-form heated evenly, and achieve high qualified-rate of product. It is suitable for heating many kinds of per-form with different size and model.

- 3) **Two-in-one Cylinder Set.** The stretch cylinder and the mouth-sealed cylinder are designed in one set, which can avoid gas leakage thoroughly and enhance the qualified-rate of product greatly. The speed of releasing each side levers can be freely regulated.
- 4) **Mold Clamping Set.** The machine adopts advanced mold clamping set. In the set, there are several mold-closed stands on the mold clamping plate. These stands increase the force of closing mold, protect the mold, warrant the quality of product, and make the mold plate sustain force evenly.
- 5) **Import Fittings.** The rubber pipe and connection made in Taiwan avoid gas leakage thoroughly. The machine's pneumatic elements, including electromagnetic valve, oil-sprayer, pressure regulator and filter, are manufactured by Taiwan using the newest technique.
- 6) **Air-stored Set.** The machine installs a compressed air-stored tank. When blowing big bottles, the machine can keep stable pressure, achieve clear bottle shape and enhance the qualified-rate of product greatly.
- 7) **Automatic Draining Set.** The machine can eliminate water and marks, emerging under high temperature and high pressure, to make product more transparent and clear.
- 8) **Protection Set.** The machine has a twin switch on set, which not only protects the mold, but also guaranties the operators' safe.

3.2. Reheating Unit

- 1) This unit is made up of mechanical part and electrical part, and equipped with control box. It is characterized of its mature heating techniques, high efficient heating effect and convenient operation and maintenance.
- 2) Its circulating move unit is made up of Main Chain-wheel, Slave Chain-wheel and Chain with cabinet volume. The whole transmission channel is divided into Heating Channels and Cooling Channels with reasonable distribution and reliable running.
- 3) This heater adopts far infrared heating lamp to reheat per-form. There are 18 heating lamps in all, which are divided into three groups. According to concrete specification of per-form, these heating lamps can be used partly or all together.
- 4) During moving ahead, the rack will make the circulating discs rotate, which can make the per-form be heated uniformly and ensure to achieve nice stretch-blow effect.
- 5) Under per-form stand-frame's long-side and short-side, there are roller, oriented track and oriented bar, which clamp correspondingly and make transmission smooth.

- 6) On cooling channels, besides natural cooling, there is fan cooling, which can quicken cooling speed to avoid accumulating heat on circulating discs. With both natural cooling and fan cooling, the heater will ensure the per-form to achieve nice heating effect.
- 7) The control box will carry out all working electrical equipments' switch & change control and adjustment, very convenient.

4. Explanation for Main Mechanism & Function of the Machine

4.1 Working-position arrangement & technical process (Diagram 1 & Diagram 2)

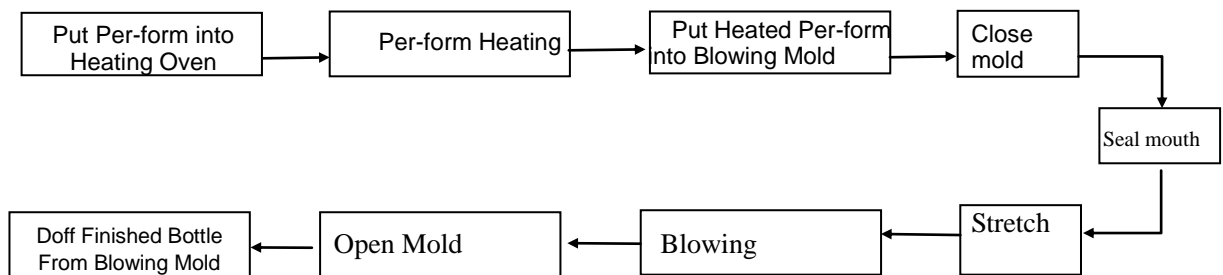
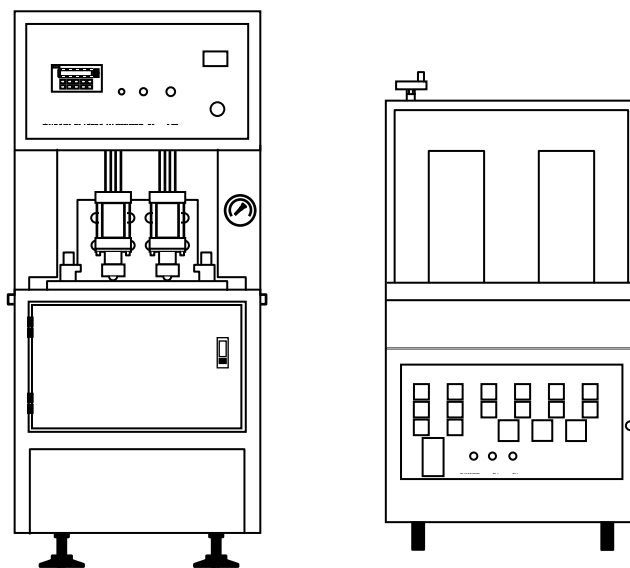
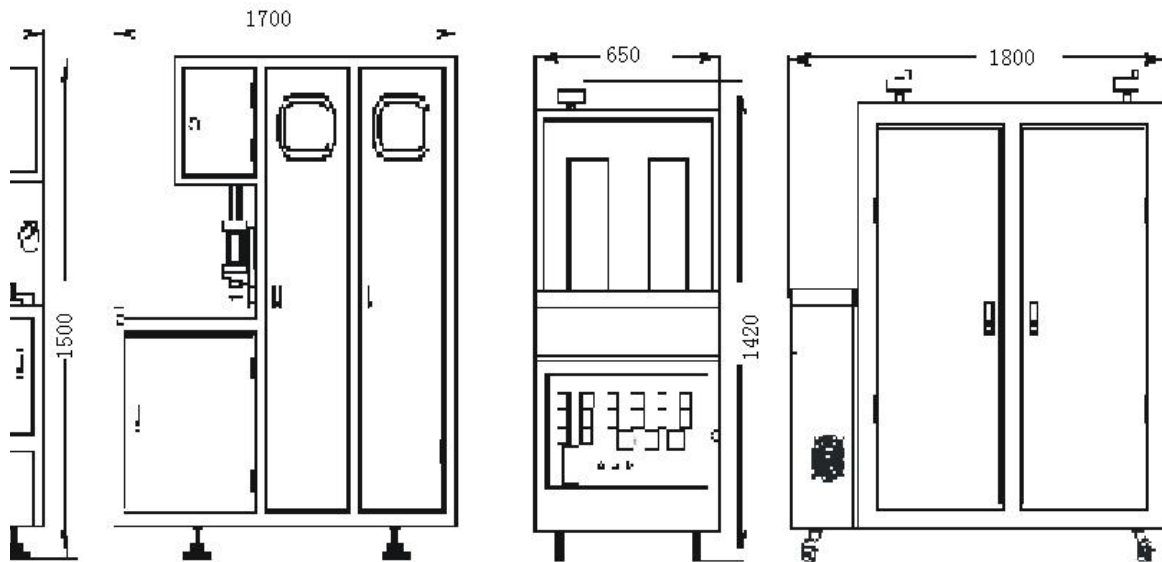

Diagram 2 Technical Process

4.2 Machine's dimension and appearance (Diagram 3)



4.3 Master Bottle Blowing Unit: (Diagram 4, Diagram 5 and Diagram 6)

It mainly consists of stretch & seal unit, mold clamping unit, mold-thickness adjusting unit, air storage unit and centralized type lubricate system. Their main function is to make sure that the figure blow from per-form is as the same as the mold shape, and meets with the technical demands.

- 1) Mold clamping unit consists of Clamping Cylinder, tie bar, Clamping Mold-Plate, Front Connect Base, Small Connect Bar, Back Connect Bar, Front Connect Bar, Front Connect Base, Support Plate, and Immobile-Mold-plate. (See Diagram 4)

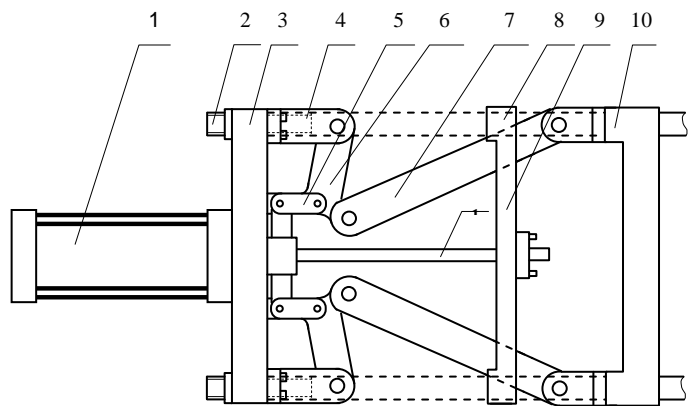

- | | |
|-------------------------------------|-----------------------|
| 1) Clamping Cylinder | 2) Tie-bars |
| 3) Clamping Mold-Plate | 4) Front Connect Base |
| 5) Small Connect Bar | 6) Back Connect Bar |
| 8) Front Connect Bar | 9) Support Plate |
| 11) Piston Bar of Clamping Cylinder | |

Basic principle: When the clamping cylinder works, the piston bar pushes the support plate, and the support plate will drive the up & down small connect bar. The small connect bar will push up the front & back connect bar to make the clamping mold-plate move backwards. The clamping mold-plate will bring the mobile mold-plate to move backwards too to clamp the mold.

- 2) Stretch & Seal Unit consists of Stretch Cylinder, Sealing Cylinder, Sealing Head, Stretch Bar, Installing Plate of Cylinder, Installing Frame of Cylinder and Fixed Block of Installing Frame (See Diagram 5 and Diagram 6)

Basic principle: When the mold closes (per-form in the mold), sealing cylinder pushes the sealing head down to seal the mouth of the per-form. After the mouth is sealed, stretch cylinders drive the stretch pole down. According to the bottle shape & per-form figure, the system delays blowing action to shape the per-form. After blowing, air in the bottles is exhausted outside to the atmosphere through exhausting valve's silencer. In the end, reset automatically. The cycle depends on the designed program to finish automatically.

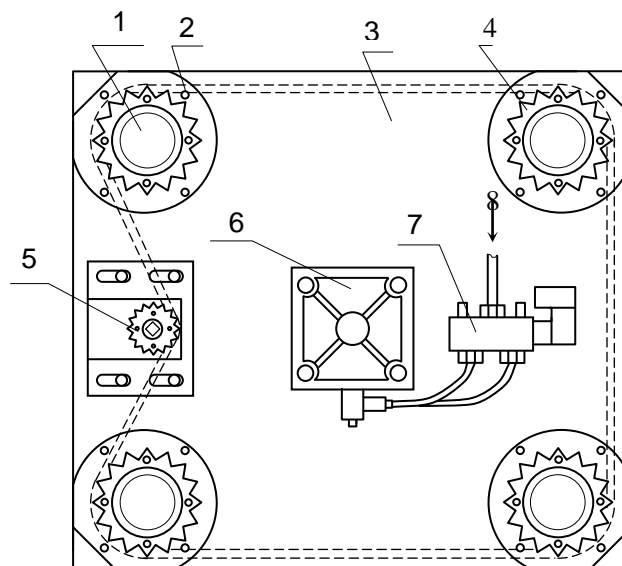
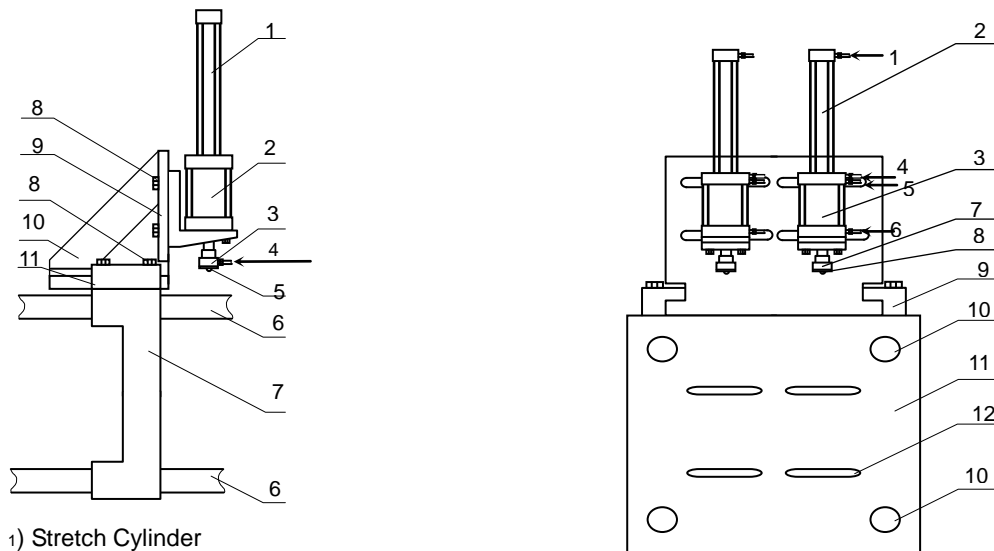

Diagram 7 Mold-thickness Adjusting Unit

- | | |
|---|----------------------|
| 1. Tie Bar | 2. Chain |
| 3. Clamp Mold-plate | 4. Gear |
| 5. Adjusting Gear | 6. Clamping Cylinder |
| 7. Action Valve | |
| 8. Low-pressure Air from Festo 3-joint Device | |

3) Mold-thickness Adjusting Unit consists of four gears connecting with tie bar, adjusting gear and chain. It is located in the back of clamp mold-plate. (See Diagram 7) Use special spanner (equipped with machine) to turn the adjusting gear; the adjusting gear will drive the chain, the chain will drive the four gears and the gears will drive the tie bar to move forward and backward. The tie bar's another end fixes with mobile mold-plate, so finally, the tie bar will bring the mobile mold-plate move forward and backward also, which will adjust the distance between mobile and immobile mold-plate to make machine suit for mold's installation with different thickness.

4) Air Storage Unit's main part is an air tank installed under machine's frame. It will store compressed air coming from air compressor. After each time blowing, the compressed air in the tank will be emitted into machine's air pipe to compensate the momentary pressure drop to keep the machine with stable pressure for next bottle blowing. (See Diagram 8)



- 1) Stretch Cylinder
- 2) Sealing Cylinder
- 3) Sealing Head
- 4) Blowing Air Entry
- 5) Stretch Bar
- 6) Tie Bar
- 7) Immobile Mold-Plate
- 8) Nut
- 9) Installing Plate of Cylinder
- 10) Installing Frame of Cylinder
- 11) Fixed Block of Installing Frame

5) Centralized type lubricate system consists of oil tank and pipeline. Its function is mainly to lubricate mold clamping unit's toggle and hinge. The pipeline has connected with toggle and hinge's each joint. After pressing the oil tank's handle several times, the lubricating oil will be input to the joint through the pipeline. (See Diagram 8)

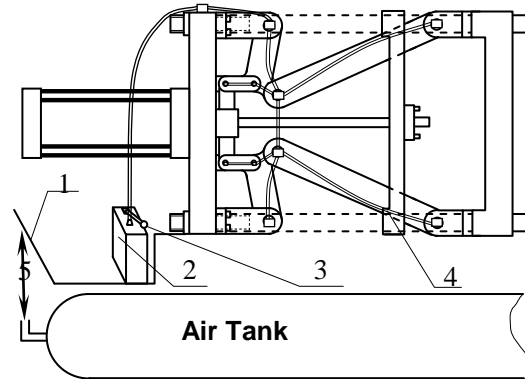

- 1. Machine's Frame
- 2. Oil Tank
- 3. Oil Tank's Handle
- 4. Pipeline
- 5. Air Entry

4.4 Per-form Reheating Units (Diagram 9)

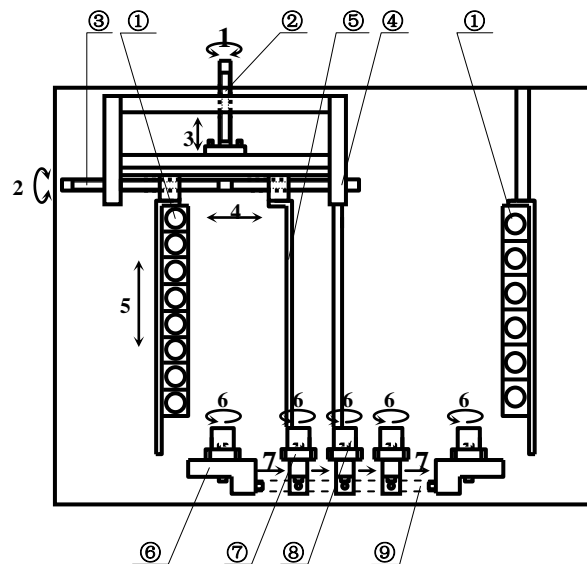

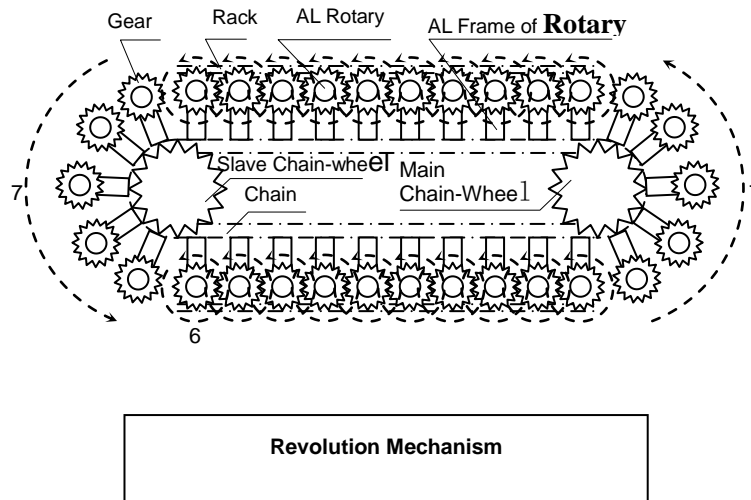

System Overview:

This system is a kind of infrared type per-form rotating & reheating unit. On normal condition, such reheating unit can heat per-form with thickness up to 6mm. It is made up of Infrared Heating Lamp (①), Adjusting Screw Bolt (②③), Standing Frame (④), Reflecting Plate (⑤), AL Frame of Rotary Disc (⑥), Gear (⑦), AL Rotary Disc (⑧) and Chain (⑨).

Combination Description:

According to different function, the whole system has been divided into mechanism of per-form feeding, rotation & revolution chain transmission, main transmission, and electric heating..

Per-form feeding set:

It consists of AL Rotary Disc (⑧), Gear (⑦) and AL Frame of Rotary Disc (⑥). It can clip per-form through the heating way, which is its main function..

Electric heating set:

It consists of 28 pcs of 600w Infrared Heating Lamp (①), Reflective Plate (⑤), Standing Frame (④) and adjusting Screw Bolt (②③). Infrared heating lamps heat per-form in the heating way, which makes the per-form get suitable temperature meeting with the demand of blow. To screw the adjusting bolt clockwise & anticlockwise (1,2), the heating lamps' installing plate will move upward & downward (3,5), leftward & rightward (4) to change the heating channel's width and heating lamps' height, which can make the reheating unit suit to heat per-form with different neck and height.

The heating voltage of Infrared Heating Lamp is controlled and adjusted by 14 pcs of potentiometers. Because such potentiometer has voltage stabilizing function, it can keep the heating lamp working on stable voltage condition. At the same time, it adopts LED display to show the voltage value, which will also be convenient for voltage adjustment.

Main transmission set:

It consists of driven motor, gearbox, transmission shaft and Mitsubishi General Purpose Inverter.

The transmission shaft will connect with machine's main chain wheel and the motor's speed is controlled by the Mitsubishi Inverter, range from 0hz to 50hz.

Rotation & revolution chain transmission set:

It consists of main chain wheel, slave chain wheel, chain and rack. Its main function ensures that per-form in the heating channels can go on both rotation (6) and revolution (7) movement.

Per-form Reheating Unit's Cooling System System Overview:

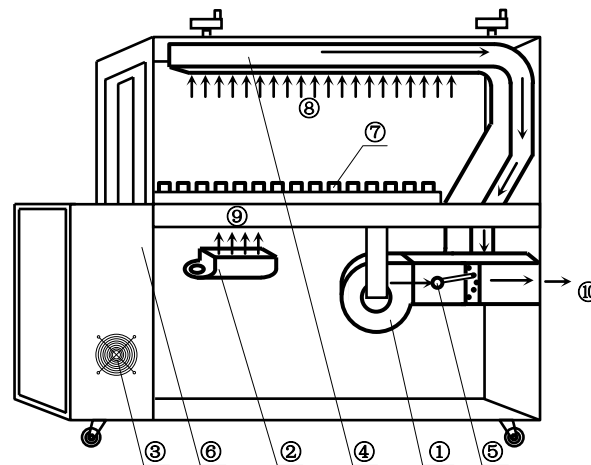

This system is made up of Exhausting Fan Motor (①), Cooling Fan Motor (②), Small Fan Motor (③), Exhausting Channels (④) and Adjuster (⑤) for Exhausting Door.

Function Description:

In order to prevent the per-form's neck from transformation after heating, Smargon-720 has adopted two methods. Firstly, all of the discs (⑦) and standing frame are made in AL alloy, which is light and durable and can emit the heat rapidly absorbed in the heating area and won't conduct much heat to per-form's neck. Secondly, whole reheating channels are divided into three heating areas and one cooling area (See Chapter of Control System). In cooling area, there is a Cooling Fan Motor (②) to blow wind upwards (⑨) to cool the AL discs and stand-frame.

In order to keep the unit with constant heating temperature, there is special designed cooling system in the reheating unit. Such system is made up of Exhaust Fan Motor (①) and Exhaust Channels (④). The channels' air input mouth locates on the upper part of the reheating unit. The hot air in reheating unit will be sucked into the channels (⑧) and exhausted into atmosphere (⑩). The arrows show the air's exhausting route. Near the channels' output mouth, there is an Adjuster (⑤), which is used to change the exhausting door's position to adjust the air exhausting flow.

There is a Small Fan Motor (④) used to cool the Reheating Unit's Electrical Control Box (⑥)..

4.5 Pneumatic system

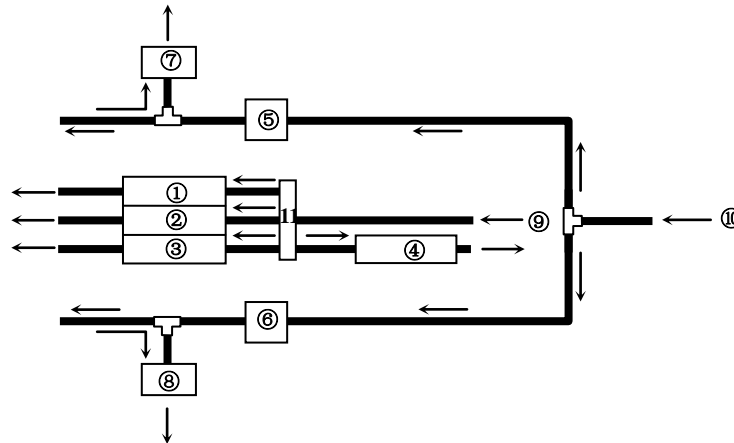

This system is made up of Bosch Action Electromagnetic Valve (①②③④), Burkert High-Pressure Blowing Electromagnetic Valve (⑤⑥) and Burkert High-Pressure Exhausting Electromagnetic Valve (⑦⑧). Their layout is as following picture. The low-pressure (8bar) compressed air is input from Air-Inlet (⑨). Thought Valve Block (11), the compressed air will be distributed to Left Stretching Valve (①), Right Stretching Valve (②), Sealing Valve (③) and Mold-Clamping Valve (④) to drive machine's each action. At the same time, the high-pressure (15~25bar) compressed air is input from Air-Inlet (⑩). Thought Left Blowing Valve (⑤) and Right Blowing Valve (⑥), the compressed air will be used to blow bottle. After blowing, the compressed air in blow mold will come back and be exhausted into atmosphere through Left Exhausting Valve (⑦) and Right Exhausting Valve (⑧)..

The machine external air source set is shown at Diagram 10. The compressed air is supplied by air-compressor, and the set must have air-source-purified function. General machine's driving air source filter precision should be <math><40\mu\text{m}</math>; blowing air filter precision is 0.5-5 μm (depends on concrete conditions). Furthermore, the circumstance temperature should below 35oC, which can ensure pneumatic part's airtight & life. The highest temperature can't exceed 45oC. **(It's very important, please be sure to keep in mind.)**

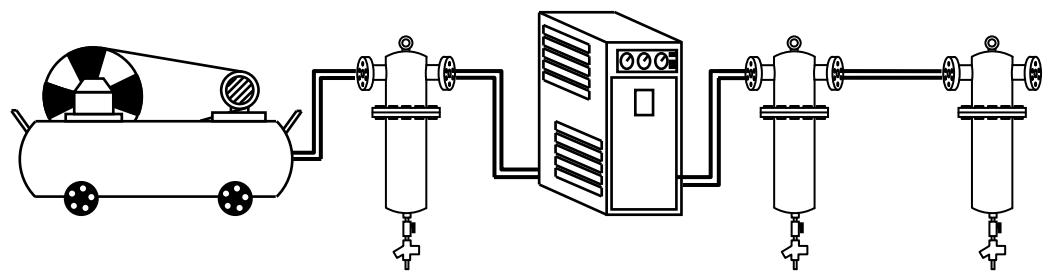

4.6 Electric System and Control System

- 1) Function introduction of master bottle blowing unit's panel (Diagram 12)

The series of BFS semi-automatic stretch blow molding machine controller uses the LSI as It's core .Which is equipped with the LCD screen. This type of controller has advantages in high dependability ,easy wire connection small cube and easy operation .It also can store the selling date for long time without the battery. The

controller has many functions such as :manual control auto control time setting and product counter etc.

The characteristics of BFS016 series are as follows:

- Hardware WATCHDOG
- Apheliotropic sum 128*64 dot. LCD display .
- EEPROM data memory .Free of battery.
- The function of calculator .

One, About panel

Control panel brief introduction:

All of the control panel can be divided into 4 areas:

- 1 Manual control area
- 2 Parameter setting area
- 3 State indication area
- 4 display area

Two, Manual control area

In this area there are seven manual control keys .All of which key can control the power of close mould valve ,seal valve ,stretch valve .lest first blowing calve. Right first blowing valve left second blowing and right second blowing.

Three, Parameter setting area

This part is used for setting the parameters of the work. First press the  key .Then the LCD screen will display :

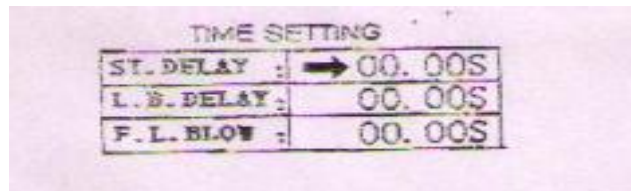

Enter the parameter-setting program. There are nine times for choice .Press the



key .Select the parameter you need .Press the key  can increase

and minus the parameter . Keep on pressing the key for one second .The data will be increased or reduced continuously .After setting p the parameter. Press ESC to store the data and come back to the main menu.



Four, State indication

This area has 23 indicator lights ,which can be divided into four groups :autolysins movement valve indicator light .timer movement indicator light .Power indicator light and button Indicator light .These are used to indicate the state .

- (1) The power indicator light will be shinning when it works in the right place.
- (2) The relevant autolysins movement valve indicator light will be shining under the operation of Manual or Automatic..
- (3) The time will be counter the time ,and timer movement indicator light will be shining under auto state .
- (4) Switch button the relevant button indicator light will be shinning when it's under auto state and the QA is start button while TA is urgent stop button.

Five, LCD display area

When the controller is working this part will display whether it's manual running or auto running .When it's under the manual condition .It won't display the number of product, but displays the 0000. When it's under the automatic condition .It will display the number of the product and show the surplus time .When it is in power the initial condition will be manual



operation. Press the key  can switch to manual or automatic stats. At the back there is a communication input ,which is used for matching the I/O unit .When you use this



controller for the first time .press the key  to select the language after connecting the power within five seconds .After you select the language cut off the power for memorization .

Six, I/O unit

The I/O unit of BFS401 series is an independently unit ,which connects with the 220Vaternating current external and communicates with the panel by the cable .There are four ways of input and eight ways output which provides the 24V direct current as well .It has two-power indicator light which will be on light when it's under the work .(connect the wire follow the wiring diagrams in the last of this operation manual).

Seven, Operate detail

- (1) Language selection

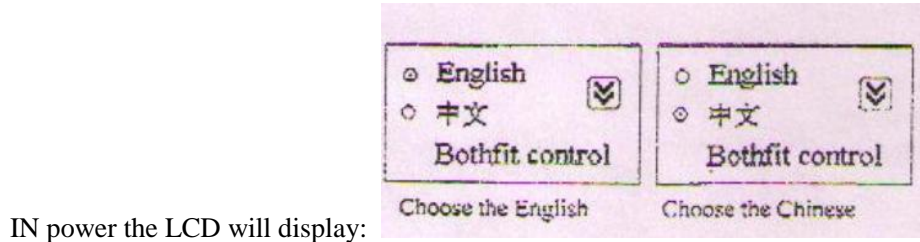

IN power the LCD will display:

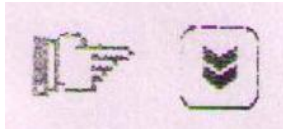

Press the set key



into the interface of the parameter setting

(2) Manual operation

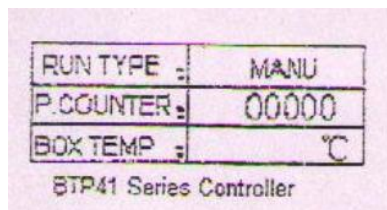

Manual display

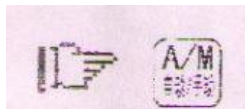

Press the button of auto/manual operation. hang the controller run into manual operation .

Press the button of auto/manual operation. hang the controller run into manual operation .



Press the close mould button .the close mould pneumatic valve will be in power then press the close mould button again ,the close mould pneumatic valve will be out of power .

Press the close mould button .the close mould pneumatic valve will be in power then press the close mould button again ,the close mould pneumatic valve will be out of power .

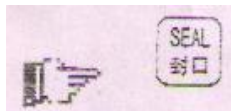

Press the seal button ,the seal pneumatic valve will be in power then press the seal button again ,the seal pneumatic valve will be out of power .

Press the seal button ,the seal pneumatic valve will be in power then press the seal button again ,the seal pneumatic valve will be out of power .



Press stretch button ,the stretch pneumatic valve will be in power, then press the stretch button again ,the pneumatic valve will be out of power ..

Press stretch button ,the stretch pneumatic valve will be in power, then press the stretch button again ,the pneumatic valve will be out of power ..



Press right first blowing button ,the right first blowing pneumatic valve will be in power ,undo the button it will be out of power .

Press right first blowing button ,the right first blowing pneumatic valve will be in power ,undo the button it will be out of power .

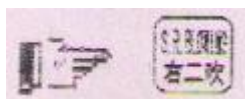

Press right second blowing button ,the right second blowing pneumatic valve will be in power ,undo the button it will be out of power.

Press right second blowing button ,the right second blowing pneumatic valve will be in power ,undo the button it will be out of power.



Press left first blowing button ,the left first blowing pneumatic valve will be in power . undo the button it will be out of power.



Press the second blowing button ,the left second blowing pneumatic valve will be in power . undo the button it will be out of power.

(3) TIME SETING

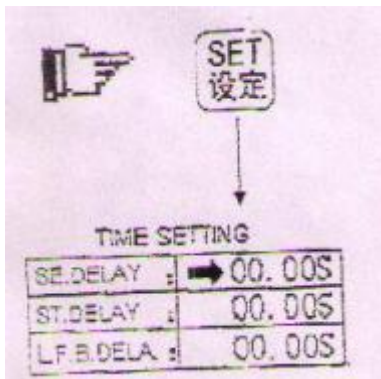

Press the key SET to enter into the setting of parameter design .

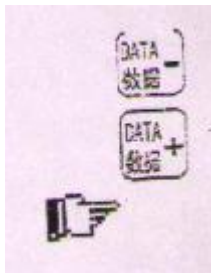

De crease the number and Increase the number .

Keep pressing the button for 1 second ,the data will increase and decrease continuously

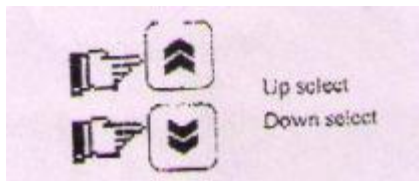

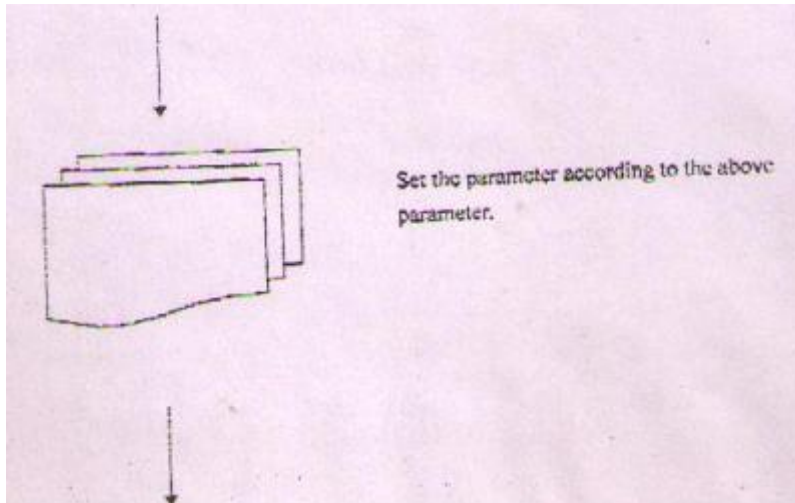

When finish the setting of parameter ,press the KEY  to store the data and return,

(4) Automatic operation:
Automatic display

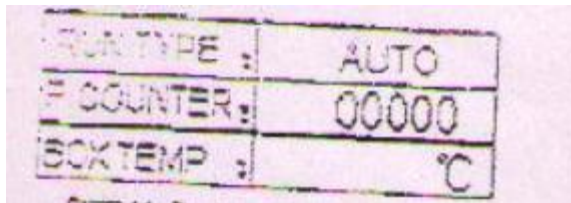

BTP41 Series Controller

After setting the parameters ,turn into automatic operation.

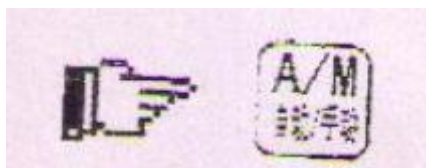

Press the auto control manual control button .Turn the controller into auto condition. Turn on the start button .the control will run automatically and counter the quantity of product automatically .IF you want to stop it immediately ,turn on the emergent stop button ,the controller will close all of the pneumatic valves .



Press the button ,then the counter will reposition to 0000.

5 Installation, Adjustment & Operation of the machine

The machine consists of master bottle blowing unit and reheating unit.

5.1 Installation of master bottle blowing unit (according to the following steps & reference diagram).

- 1) According to the working position, you can select a suitable installing position. See Diagram 1
- 2) Hang the machine from the wooden foundation, and lay down on the even earth. The machine's standing foot is as Diagram 17.
- 3) Adjust level. See Diagram 18

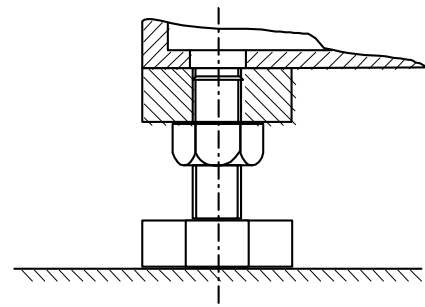

Diagram 17 Standing Foot

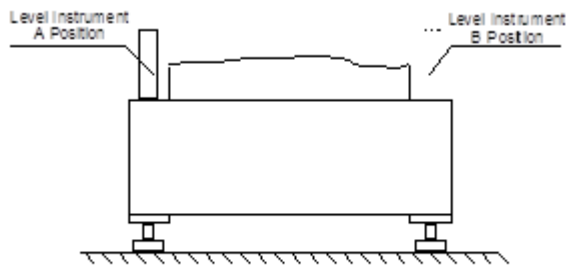

Diagram 18

Level-adjusted Steps (Master bottle blowing unit):

- (1st). Place the master bottle-blowing unit on the concrete earth & 1st grade level instrument on the left of the master unit.
- (2nd). Observe reading of level instrument, for example, “0” position +2 is in the visible standard range.
- (3rd). If reading is out the range, then, find the foot of the machine corresponding to the end, which is bigger in reading.
- (4th). Loose the nut on the foot clockwise and rotate the foot with screw anticlockwise slowly using wrenches, observing the cursor until it is in the prescriptive range.
- (5th). At that time, loose the wrenches, then, screw down the nut anticlockwise.
- (6th). After adjusting at the left of the machine, places level instruments to right sides and do that as above steps.

Certainly, you can also adjust level at the foot of the machine on the opposite side of the end that is bigger reading. **The method is:** At first, loose the nut; rotate the foot clockwise with wrenches, observing the cursor until it is in the prescriptive range. At last, screw down the nut with wrenches.

Please note: The master bottle blower machine’s adjustment is very important step that ensures the machine to run normally. Do not neglect this technical step, operators!

4) Power Connection. There has been an electrical wire connecting from master blowing unit’s junction box. You only need connect the wire with power supply. The wire has two lines, one is fire line and the other is Zero line. So machine’s input voltage is 220v/1ph/50hz.

(2nd). Most of the high-pressure compressed air will go to Burkert Blowing Valve through high-pressure filter.

(3rd). Part of the high-pressure compressed air will be decompressed to 10bar through the high-pressure decompressed valve .

(4th). The 10bar compress air will go through Festo Pneumatic 3-joint element to get rid of the water content, oil content and be decompressed again to 8bar

(5th). The purifying 8bar compressed air will go to Festo Valve to drive machine’s action

So, you need only connect the outside air input pipe with machine’s air input valve, and then finish the air-input installation.

Smargon-720’s another air-input mode is to use two air compressors as machine’s air supplier. Thereinto, the low-pressure one supplies driven air and the high-pressure one supplied blowing air. On such mode, we will cancel the high-pressure decompressed valve and install two independent air input valves. Then the low-pressure air will go to Festo 3-joint element and the high-pressure air will go to high-pressure filter respectively. So, you should connect the two air-input valves with different outside air-input lines. In following chapter, you will find detailed information about such two

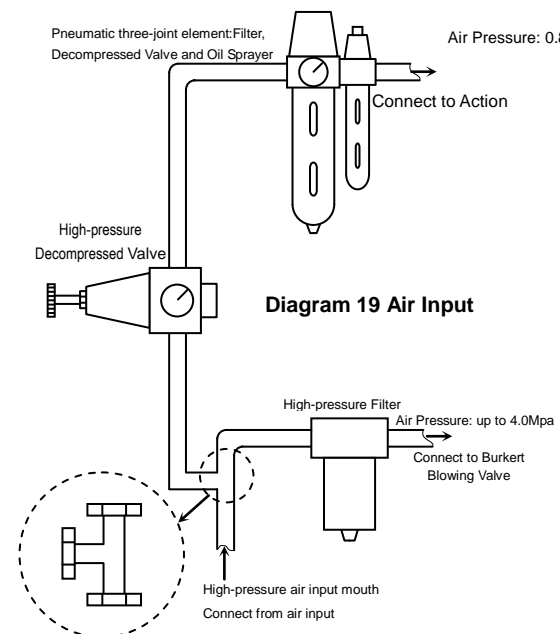

kinds of air input mode.

Air Input Description of Mode A:

This system is designed for the condition to use only one pc of High-Pressure Air Compressor as machine’s air supplier. It is made up of FESTO Pneumatic 3-joint Device (①): Filter, Decompressed Valve & Oil Separator, High-pressure Decompressed Valve (②), High-pressure Filter (③), T Junction (④) and Pipeline (⑤).

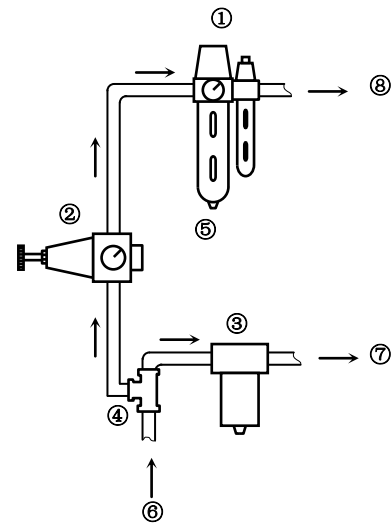

Air Input Description of Mode A:

- 1) The high-pressure compressed air (15~30bar) will be input from the air-input valve (⑥).
- 2) Most of the high-pressure compressed air will go to Burkert Blowing Valve (⑦) through High-pressure Filter (③)
- 3) Part of the high-pressure compressed air will be decompressed to 10bar through High-pressure Decompressed Valve (②)
- 4) The 10bar compressed air will go through Festo Pneumatic 3-joint Device (①) to get rid of the water content, oil content and be decompressed again to 8bar
- 5) The purifying 8bar compressed air will go to Bosch Action Valve (⑧) to drive machine’s action

So, you need connect the outside air input pipe coming from the High-Pressure Air Compressor with machine’s air input valve (⑥).

System Overview of Mode B:

This system is designed for the condition to use two Air Compressors as machine’s air supplier. There into, the low-pressure one supplies driven air and the high-pressure one supplied blowing air. It is made up of FESTO Pneumatic 3-joint Device (①): Filter, Decompressed Valve & Oil Separator, High-pressure Filter (②) and Pipeline (③④).

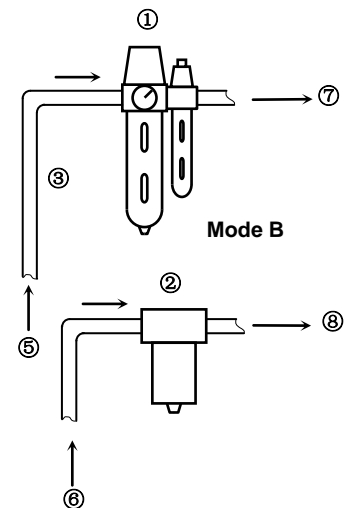

Air Input Description of Mode B:

- 1) The high-pressure compressed air (15~30bar) will be input from the air-input valve (⑤).
- 2) The 15~30bar compressed air will go to Burkert Blowing Valve (⑧) through High-pressure Filter (②)
- 3) The Low-pressure compressed air (10bar) will be input from the air-input valve (⑥).
- 4) The 10bar compressed air will go through Festo Pneumatic 3-joint Device (①) to get rid of the water content, oil content and be decompressed again to 8bar. The purifying 8bar compressed air will go to Bosch Action Valve (⑦) to drive machine’s action

So, you need connect the two air-input valves (⑤⑥) with different outside air-input lines from different Air Compressors.

5.2 Installation of Stretch-Seal Cylinder

- (1st). Fix the cylinder on installing-plate using nuts. (See Diagram 5)
- (2nd). Connect the air pipe to cylinder’s No1, No4, No5 and No6 air entry. The pipes’ another end connects with Festo Sealing and Stretch valves respectively. (See Diagram 6)

(3rd). Connect the air pipe to sealing head's No4 air entry. The pipe's another end connects with Burkert Blowing valve. (See Diagram5)

Please note: On cylinder's air-input entry and valve's air-output entry, we have all equipped with special tie-in. So, only one thing you should do to connect the cylinder and valve is to insert the air pipe into their tie-in directly.

(4th). Turn on the air-input valve to input the compressed air..

(5th). Adjust PLC to Manual Mode and press the action buttons one by one to see if the cylinder can work normally and if there is air leakage on the joint part.

(6th). If there is air leakage

- 1) Turn off the power supply and the air-input valve
 - 2) Loose the Festo filter's drain valve to discharge all the compressed air in the pipe; then tighten the drain valve again
 - 3) Pull out the air pipe from tie-in and insert it again
 - 4) Turn on the air-input entry
- Repeat above step till the air leakage has been gotten rid of.

On Smargon-720, we have installed four Bosch valves and four Burkert valves. Thereinto, one Bosch valve will be used for clamping mold, one for Sealing and the other two for Stretching; four Burkert valves will be divided into two groups, each group will including one blowing valve and one exhausting valve and be in charge of one cavity blowing respectively.

5.4 Installation of the Reheating Unit

- 1) Place the reheating unit on even earth, according to the working-position arrangement Diagram (See Diagram 1)
- 2) Power Connection. On the reheating unit's junction box, we have installed four joints on the connecting set. You should use suitable electrical wire to connect the joints with power supply. As regards the four joints, also three should be connected with fire line and the other with Zero line. So reheating unit's input voltage is 380v/3ph/50hz too.

5.5 Installation & Adjustment of the Mold

(1st). There are four long grooves on mobile and immobile mold-plate (See Diagram 6). The mold-installing nut will screw into the mold through the long grooves to fix the mold onto mold-plate.

(2nd). Turn on master blowing unit's power switch and air-input valve

(3rd). Input high-pressure compressed air higher than 10bar to master blowing unit

(4th). Check the distance between mold's installing hole and its upper surface to see if it accords with mold-plate's installing long grooves.

(5th). Prepare four ϕ 12x40 screws and several shims (supplied with the machine)

(6th). Adjust PLC system to Manual Operation mode and press Mold button to open the mold plate.

(7th). Turn off power switch and air-input valve

(8th). Turn on the Festo filter's drain valve to discharge the remaining compressed air in the air pipe, then turn off the drain valve again.

CAUTION: above two steps can avoid starting up the machine by chance and prevent the operator

from injury. Please don't ignore it!

(9th). Unload master blowing unit's front, left and right doors

(10th). Under mold-open state, install the half mold without bottom onto the mobile mold-plate as following step:

- 1) Put a thick long wooden board on machine's two below tie-bars
- 2) Put the half mold without bottom on the wooden board
- 3) Move the wooden board to bring the half mold between the tie-bar
- 4) Put up the wooden board's on side to make the half mold's one installing hole coincide with mold-plate's long groove
- 5) Screw down the nut into the hole through long groove
- 6) Put up the wooden board's another side to make the half mold become horizontal, then screw down the nut into another hole
- 7) Move the half mold along the long groove to make the mold locate in the middle of mold-plate
- 8) Finally, tighten the nuts using special spanner to fix the half mold onto mobile mold-plate

(11th). Put the other half mold onto the former half one according to its locating pin and the former's locating hole.

(12th). Turn on the power switch and air-input valve again

(13th). Press PLC controller's Mold button again to close mold

(14th). On mold-close state, according to mold's thickness to adjust the distance between mobile and immobile mold-plate as following step. Finally, make the mold close in line completely.

1) There is special mold-thickness adjusting unit behind machine's clamping mold-plate (see Diagram 7). Each tie-bar connects with gear and all gear is connected by chain.

2) Using special spanner to rotate the adjusting gear's rhombic end. Then, the adjusting gear will drive the chain, the chain will drive the four gears, the four gears will drive the four tie-bars, and the four tie-bars will drive the mobile mold-plate move forward or backward to clamping different mold firmly.

(15th). After adjustment, screw down the nuts into the half-mold with bottom through immobile mold-plate

(16th). Press PLC controller's Mold button for several times to ensure machine's mold close-open movement is smooth and fine.

(17th). Load master blowing unit's front, left and right doors and adjust the machine enter into Semi-Auto State finally.

5.6 Adjustment of Sealing mouth & Stretch

(1st). After install mold, press PLC's "Mold" button to close mold

(2nd). Loose the nuts on stretch-seal cylinder's installing plate and installing frame's fixed block (see Diagram 5)

(3rd). Move the stretch-seal cylinder leftward and rightward along the long groove on installing frame (see Diagram 6)

(4th). Move the installing frame forward and backward along the fixed block (see Diagram 5)(Through above two steps to make the sealing head on the cylinder just locate above the mold's mouth

(5th). Press PLC's "Seal" button to move down the sealing head to seal the mold's mouth

(6th). Press PLC's "Stretch" button to move down the stretch bar

(7th). Press PLC's "Mold" button again to open mold

(8th). Turn off power switch and air-input valve

(9th). Turn on the Festo filter's drain valve to discharge the remaining compressed air in the air pipe, then turn off the drain valve again.

CAUTION: above two steps can avoid starting up the machine by chance and prevent the operator from injury. Please don't ignore it!

(10th). Repeat above step (3rd.) and (4th.) to make the stretch bar coincide with the mold bottom's center.

(11th). Tighten the nuts on stretch-seal cylinder's installing plate and installing frame's fixed block to fix the cylinder and installing frame

(12th). Turn on the power switch and air-input valve again

(13th). Press PLC's "Stretch" and "Seal" buttons to lift the stretch bar and sealing head and finish adjustment.

CAUTION: Top screws of stretched bar can not be tightened. They should keep loose condition.

5.7 Operation of Bottle Production

(1st). Turn on reheating unit's power and the switch of electric heating and fan

(2nd). Turn on the six potentiometers and adjust to suitable voltage according to requirement

(3rd). When the temperature in heating channels rise to suitable degrees, put several per-form into the channels for a try.

(4th). After preheating, put the heated per-form into the mold and press two "Start up" buttons at the same time. Then, the following procedure can be completed automatically: Close mold → Sealing Head down → Stretch Bar down → Blow → Exhaust → Stretch Bar up → Sealing Head up → Open mold

The procedure will go round and round. If the blowing test is successful, you can put per-form into reheating unit formally for heating.

Note Item:

1. Reheating unit's controllable silicon short must be avoided.
2. Heating channels' temperature must be adjusted by controllable silicon voltage adjuster or adjusting exhaust fan's fan plate. Please be sure of not using temperature controller to adjust temperature.
3. When general working motor starts up, its speed must be adjusted to slow level firstly.

Sealing speed, stretched-lever speed, blowing speed and blowing time are controlled by four digital time relays. The products' quality depends on many factors, including quality of per-form, thickness of per-form, shape of products and so on. When you have a blowing test, the time parameter should be adjusted frequently, especially blowing time.

6. Maintenance of the machine

Master Blowing Unit:

1. Operator should add grease timely to the parts where has grease input mouth. It can assure that these movable parts always keep good lubricating condition.

2. Make sure that there is enough oil in the oil sprayer (The oil level can't below 1/3 of the full Voltmeters), and the model of the oil is 15# white oil.
3. Fixed screws of every part should be checked every week at the same time.
4. The dirty water in the air filter should be drained every day.
5. Earth wire should be fixed for safety.
6. Keep the machine clean and avoid rusting and damaging elements in it.

Master Blowing Unit:

1. The machine's cleanness should be kept everyday to prevent its elements from destroying.
2. All electrical equipments' connect ends must be connect correctly and firmly.
3. Keep cleanness of switch buttons' indicator to ensure correct operation.
4. Check if machine's fixed nuts has loosen or destroyed frequently.
5. Keep running part's lubricating condition and gearbox's oil face.
6. When installation, the machine's frame must be connected to earth to ensure safety.

7 Problems and solution

Problem	Reason	Solution
No movement with mold or move too slowly	1. Electromagnetic valve of mold-closed is off or is damaged 2. Air pressure is lower 3. Sealing ring of piston on the mold-closed cylinder is damaged	1. Check corresponding electric circuit or change the valve 2. Adjust air pressure 3. Change sealing ring
No seal movement or seal too slowly	1. Electromagnetic valve of mouth-sealed is off or is damaged 2. Air pressure is lower 3. Sealing ring of piston on the mouth-sealed cylinder is damaged	1. Check corresponding electric circuit or change the valve 2. Adjust air pressure 3. Change sealing ring
No movement with stretch lever or move too slowly	1. Stretch electromagnetic valve is off or is damaged 2. Air pressure is lower 3. Sealing ring of piston on the stretch cylinder is damaged	1. Check corresponding electric circuit or change the valve 2. Adjust air pressure 3. Change sealing ring
No blowing movement	Blowing electromagnetic valve is off or is damaged	Check corresponding electric circuit or change the valve
Programmed control is not normal	1. Hand switch is not reset 2. Some electric elements are damaged	1. Reset hand switch 2. Change electric elements

1. Master Blowing Unit

2. Reheating Unit

Problem	Reason	Solution
No action of general working motor	<ol style="list-style-type: none"> 1. Not turn on power supply 2. Motor is broken 	<ol style="list-style-type: none"> 1. Check electro circuit and switch 2. Repair or change motor 3. Check if the fuse is broken 4. Check gears' cooperation
No action of cooling fan or exhaust fan	<ol style="list-style-type: none"> 1. Not turn on power supply 2. Corresponding motor is broken 3. Fan is broken 	<ol style="list-style-type: none"> 1. Check electro circuit and switch 2. Repair or change motor 3. Repair or change fan
Far infrared heating lamp don't work	<ol style="list-style-type: none"> 1. Not turn on power supply 2. Bad touching condition on lamps' both ends. 3. Lamps are broken 	<ol style="list-style-type: none"> 1. Check electrocircuit and switch 2. Adjust touching condition 3. Change heating lamp
Controllable silicon voltage adjustment is out of order	<ol style="list-style-type: none"> 1. Electro circuit failure 2. Elements are broken 	<ol style="list-style-type: none"> 1. Check electro circuit and switch 2. Change elements
Transmission stand-frames don't run smoothly	<ol style="list-style-type: none"> 1. Main and slave chain-wheel are tilted or broken 2. Chain is broken 3. Idler wheel, rack and oriented track haven't touched well or are broken. 	<ol style="list-style-type: none"> 1. Check main and slave chain-wheel, adjusting or changing 2. Check chain, adjusting or changing 3. Check Idler wheel, rack and oriented track, adjusting or changing
Controller can't work normally	<ol style="list-style-type: none"> 1. Not reset Manual mode 2. Electrical elements are broken 	<ol style="list-style-type: none"> 1. Reset Manual mode 2. Change control Plug board

8 Abnormal Phenomenon and treatment

Abnormal Phenomenon	Reason	Solution
Bottle can not be shaped	<ol style="list-style-type: none"> 1. Air pressure is lower 2. Oven temperature is not correct 3. Stretched-lever's speed is not correct 	<ol style="list-style-type: none"> 1. Adjust pressure of air pump 2. Adjust the temperature 3. Adjust the speed
Moon-like agglomerate on neck or bottom	<ol style="list-style-type: none"> 1. Stretched-lever's speed is not correct 2. Oven temperature is not correct 3. Per-form structure is not suitable 	<ol style="list-style-type: none"> 1. Adjust the speed 2. Adjust the temperature 3. Change the per-form
Bottom of the bottle is not even and symmetrical	<ol style="list-style-type: none"> 1. Stretched-lever's speed is too fast 2. Temperature of oven's lower part is too high 	<ol style="list-style-type: none"> 1. Adjust the speed 2. Adjust the temperature
Lines of the bottle are not clear	<ol style="list-style-type: none"> 1. Oven temperature is too low 2. Oven temperature is too high (if there is milky white color on the bottles) 	Adjust the temperature

1. Master Blowing Unit

2. Reheating Unit

Abnormal Phenomenon	Reason	Solution
Heating channels' temperature isn't even.	<ol style="list-style-type: none"> 1. Exhaust fan isn't adjusted well 2. Far infrared heating lamps aren't adjusted well 	<ol style="list-style-type: none"> 1. Adjust exhaust fan's plate 2. Adjust infrared heating lamps
Per-form can't stretch-blow into bottle	<ol style="list-style-type: none"> 1. Heating time is too long 2. Heating temperature is too high 3. Heating time is too short 4. Heating temperature is too low 	<ol style="list-style-type: none"> 1. Shorten heating time 2. Lower heating temperature 3. Prolong heating time 4. Raise heating temperature
Per-form's mouth is softened	<ol style="list-style-type: none"> 1. Cooling channels' temperature is too high 2. Far infrared heating lamps' temperature is too low 	<ol style="list-style-type: none"> 1. Adjust cooling fan 2. Adjust controllable silicon voltage adjuster.

Electrical principal diagram

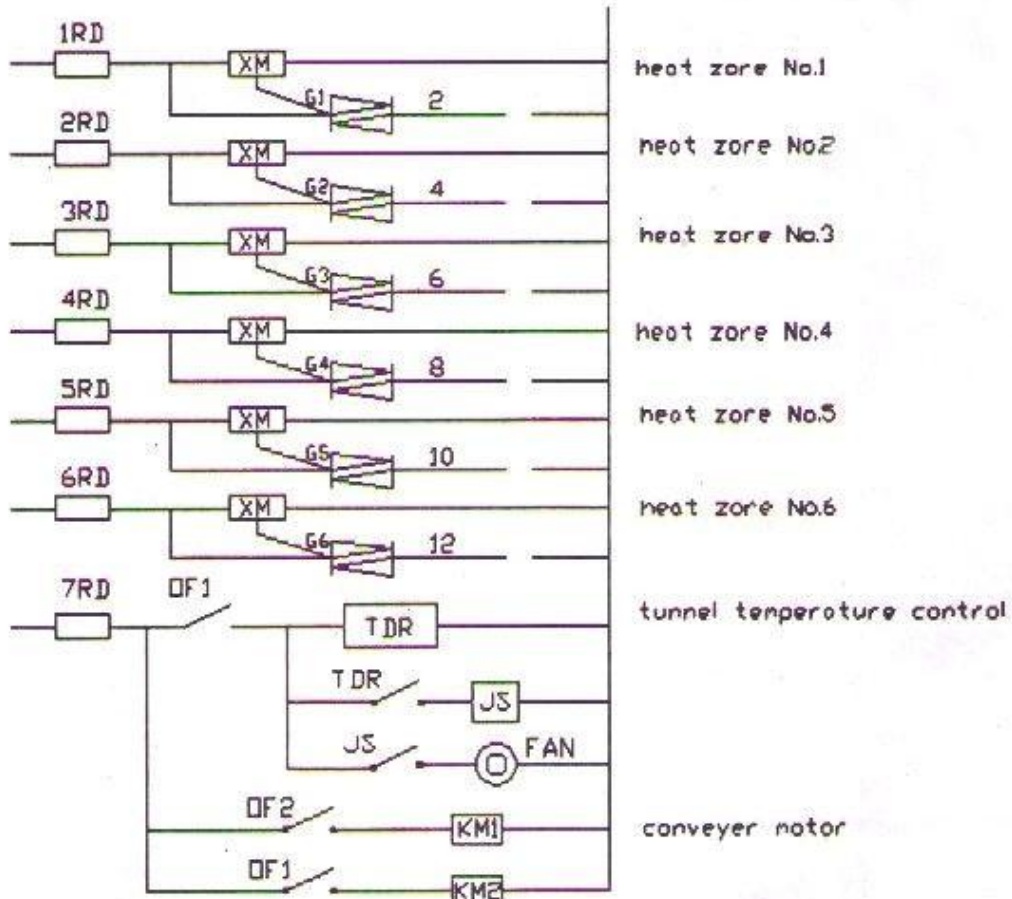

Micro-computer wiring diagram

